

LESSON PLAN

TITLE: ROTOR MOTOR

GRADE RANGE: 3-5

SUBJECT: SCIENCE

BENCHMARK: SC.C.1.2.1 – The student understands that motion may be described, measured and predicted.

DESCRIPTION OF THE LESSON: Arranged in teams or constructive groups, students will cutout and construct the provided rotor motor template. A series of investigations predicting the number of rotations will determine the affect of drop height on the on the rotor motor.

BACKGROUND INFORMATION: Air must move across the surface of a wing to produce lift. To fly, birds and insects use a flapping motion to move the air over and around the wing surface. The wings of airplanes are attached to the fuselage in a fixed position. Lift is generated by moving the entire wing and body through the air. *Helicopters are rotary wing aircraft*; they rotate the wing surface through the air to produce lift.

MATERIALS (per group of students)

Plain white paper

Graph paper

Student Page with template and graph

Scissors

Measuring tape

Pencil or marker

3 m. length of lightweight paper ribbon for a strip of audiotape or videotape

ESSENTIAL QUESTION (PROBLEM STATEMENT): What is the relationship between the number of twists and the drop height of a rotor motor?

OPENING: Begin by describing air and the lift produced by airflow and air pressure exerted on an airplane or helicopter.

STEPS TO DELIVER LESSON: (Please refer to the attached.)

1. Arrange class into teams or collaborative groups of three or four.
2. Cutout and assemble the rotor motor design.
3. Drop rotor motor at varied heights.
4. Experiment to comparative rate of descent using unfolded paper, folded paper and the rotor motor.
5. Repeat experiment, predicting rate of descent and rotations to drop height of release using attached cassette ribbon to count.
6. Predict results, constructing a bar or line graph to show the relationship between the number of twists and the drop height of the rotor motor.

LESSON CLOSURE: As a whole class, discuss data including relevant variables. Encourage extended inquiry questions and suppositions.

HOME LEARNING: Compare and contrast how helicopters and airplanes fly. List safety concerns pilots address when flying aircraft. Suppose you are Leonardo de Vinci, how would you have viewed birds' flight to create a rotor motor similar to a helicopter?

ROTOR MOTOR

Objectives

The students will:
Construct a rotary wing model.
Define a mathematical relationship using a model.

Standards and Skills

Science

Science as Inquiry
Physical Science
Position and Motion of Objects
Science and Technology

Science Process Skills

Observing
Making Models
Controlling Variables

Mathematics

Problem Solving
Estimation
Measurement
Graphing

Background

Air must move across the surface of a wing to produce lift. To fly, birds and insects use a flapping motion to move the air over and around the wing surface. The wings of airplanes are attached to the fuselage in a fixed position. Lift is generated by moving the entire wing and body through the air. *Helicopters* are rotary wing aircraft; they rotate the wing surface through the air to produce lift.



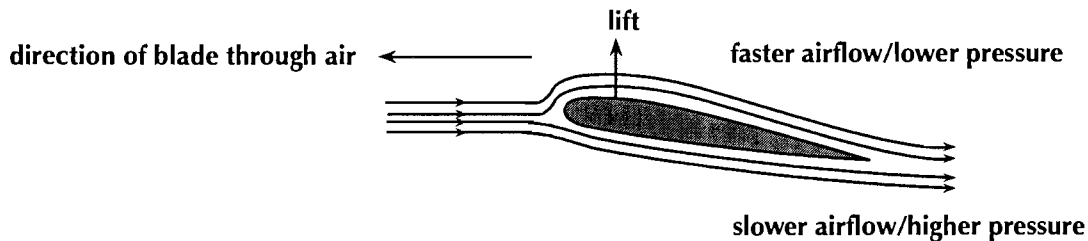
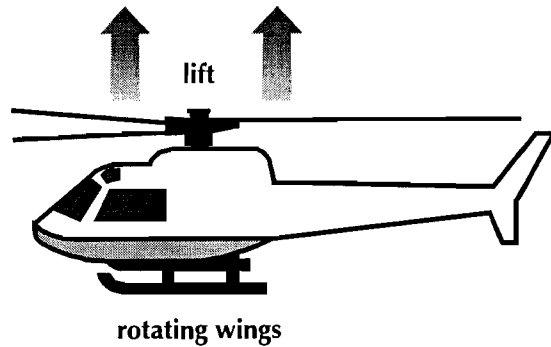
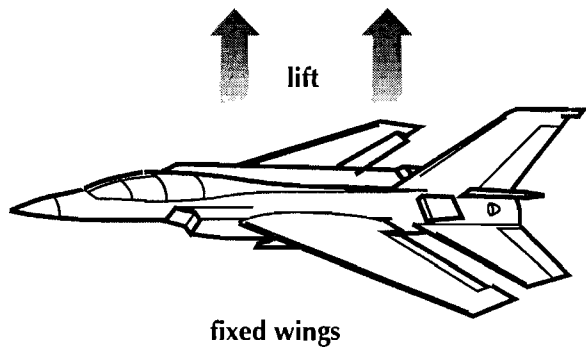

cross section of aircraft wing, or a rotor blade

Lift is produced by the pressure differences caused by the shape of rotating blades; this is the same way lift is produced by aircraft wings. The rapidly moving air over the top of the blade creates low pressure; the air beneath the blade is moving slower, so it creates higher pressure (see "Paper Bag Mask" pages 26-27, Bernoulli's principle, for more information). High pressure under the rotor blades creates lift which causes the aircraft to rise.

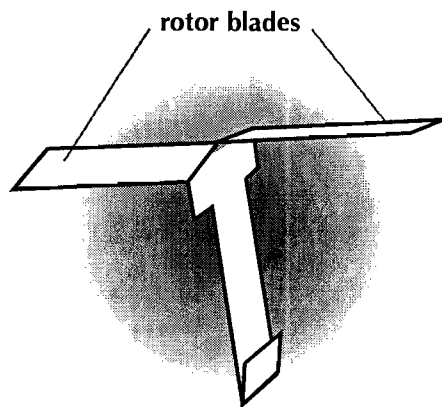

paper model

Since the paper models have no motor, they only have one source of lift. As the paper models fall they will spin, imitating the rotation of the rotor blades of a helicopter. Because there is no thrust to produce upward movement, the helicopter will not fly upward, but the spin will reduce the rate of fall by producing lift, resisting the force of gravity.

NASA builds and tests experimental helicopters and *tiltrotor* airplanes in an effort to achieve lower noise levels and greater fuel efficiency. Models are tested in NASA's wind tunnels at Langley, Lewis, and Ames Research Centers.

Materials

Plain white paper
Graph paper
Student Page with template and graph
Scissors
Measuring tape
Pencil or marker
3 m length of lightweight paper ribbon (or a strip of audiotape or videotape)

Management

The activity will take approximately 30-45 minutes.

Preparation

Open an old audio or videotape cassette and show the class the tape inside the cassette. The tape will be used for the activity.

Team students with a partner or in cooperative groups of three or four.

Make enough copies of the rotor motor template so each team may construct a rotor motor. Have students use the template to construct rotor motors.

Activity

1. Cut along the solid lines of the template.

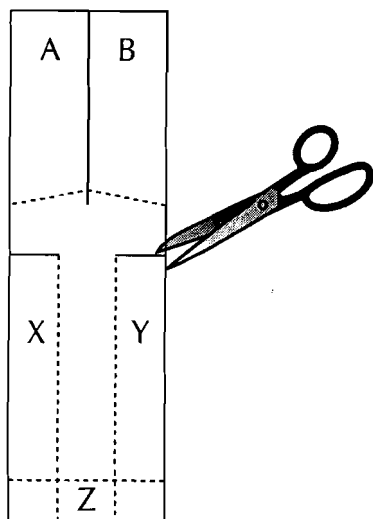

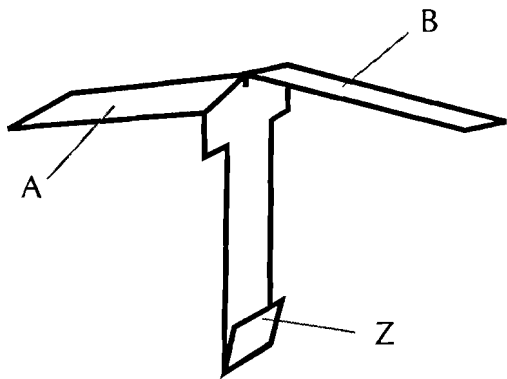

2. Fold along the dotted lines. The propeller blades should be folded in opposite directions. X and Y fold toward the center, and Z is folded up to give the body rigidity, and lower the center of gravity.
3. Stand up and drop the rotor motor. Have the students write or draw what they observed.
4. Drop an unfolded piece of paper and the rotor motor. Which one falls faster? *The paper falls faster because it is not continuously generating lift. The spinning rotor motor reduces the rate of fall by producing lift, resisting the force of gravity.*
5. Have the students predict what will happen when they wad up the paper and drop it. *It will drop faster than the sheet of paper and the rotor motor. The sheet of paper falls slower mainly because its larger surface area offers more resistance to the air than the compact, wadded paper.*

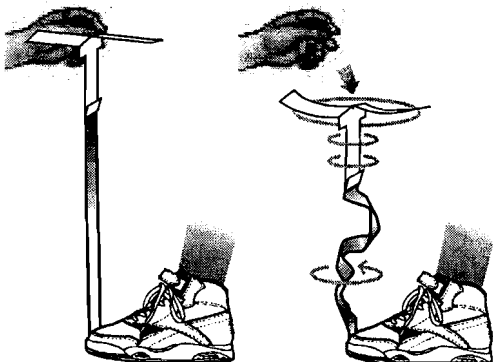
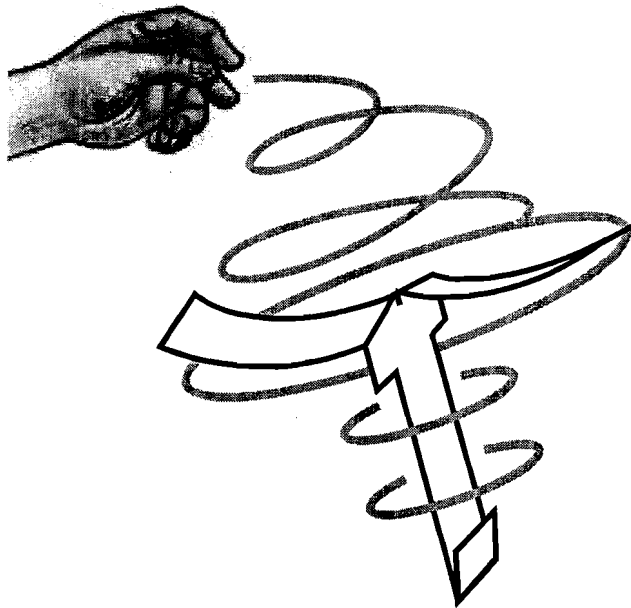

6. Can you accurately count the number of rotations the rotor motor made as it descended? *No—the rotations are fast and that makes accurate counting very hard.*
7. To determine the number of rotations, (1) tape the cassette ribbon to the rotor motor, (2) stand on the loose end, and pull the rotor up so there are no twists in the ribbon, and (3) drop the rotor as usual. How does the cassette ribbon make counting the rotation easier? *Each twist in the ribbon represents one rotation of the rotor motor. Counting the total number of twists equals the total number of rotations.*

Assessment

1. The teacher can observe the construction activities in progress.
2. Formulate a rule describing the relationship between the number of twists and the drop height of the rotor motor.

Extensions

1. Have students experiment with helicopters made from different weights of paper. Graph the results.
2. Have students design a new rotor motor.
3. Have students determine relationships between the weight, height of launch, shape, and length of the blades.
4. Have students determine whether the blades turn in a clockwise or counterclockwise direction.
5. Have students increase and decrease the angle of incidence (see illustration) of the rotor blades, and determine if the new angles make the rotor motor rotate faster or slower, and if it flies longer.
6. Have students compare the flight of the rotor motors to that of a maple seed or a dandelion.
7. Seasonal variation: design paper helicopters shaped like bunnies, ghosts, or reindeer.
8. Construct a bar or line graph that shows the relationship between the number of twists and the drop height of the rotor motor.

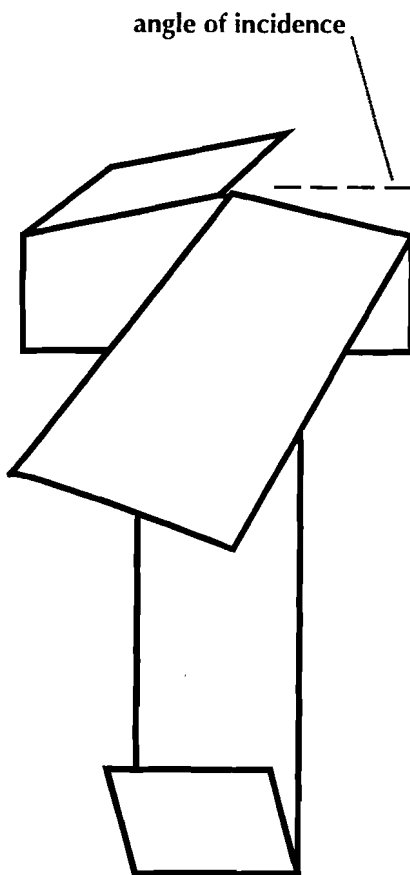

Rotor Motor Templates

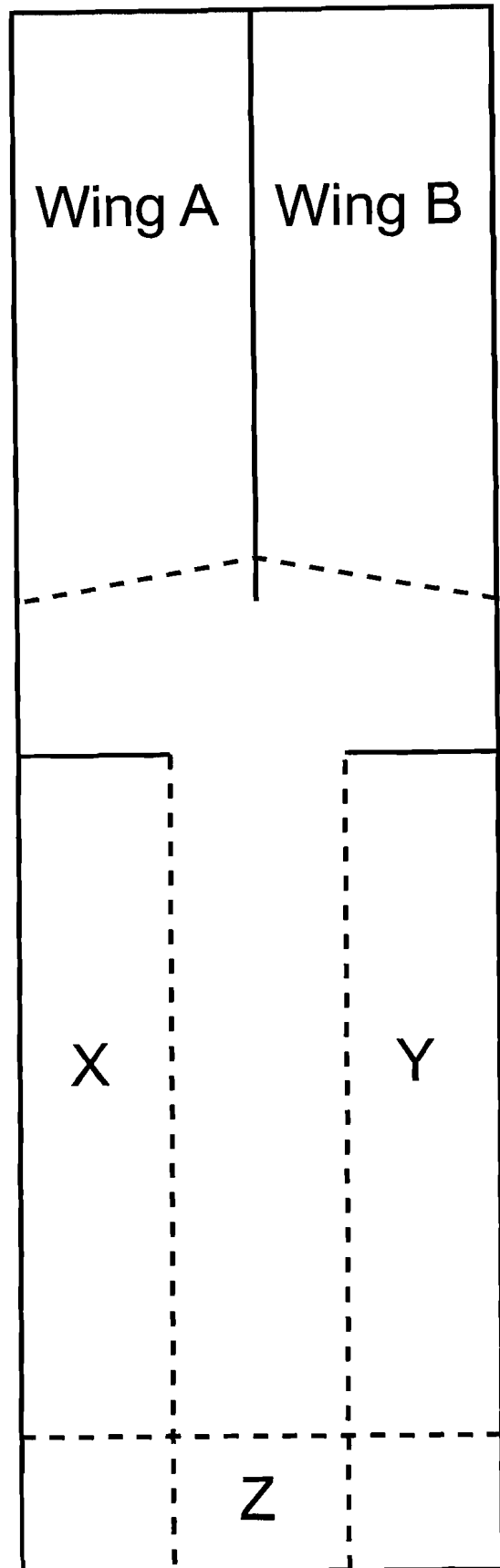
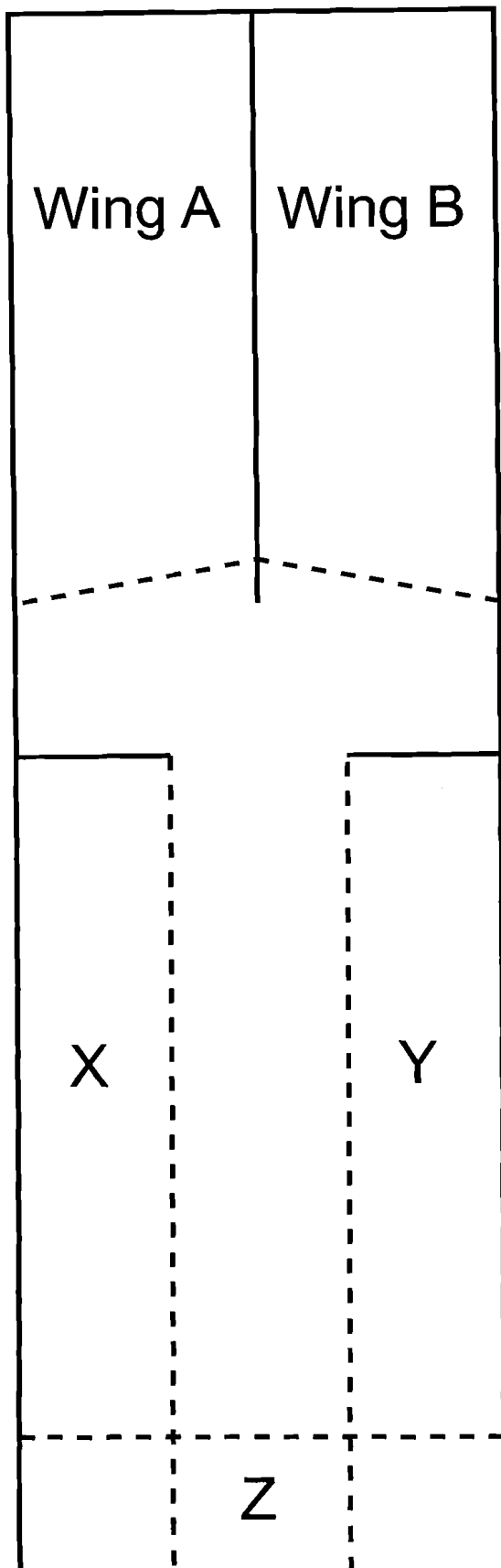



Rotor Motor

